



**YAMAHA MOTOR CORPORATION, U.S.A.**

6555 KATELLA AVENUE, CYPRESS, CALIFORNIA 90630-5101 714/761-7300

07V-039  
(9 pages)

February 6, 2007

Via Federal Express and Facsimile (202 366 7882)  
Chief Administrator  
National Highway Traffic Safety Administration  
Associate Administrator for Safety Assurance  
400 Seventh Street, SW  
Washington, DC 20590

**Regarding: 2002 - 2007 Year Yamaha XV1700 (Warrior)  
Pick-up Coil Factory Modification Campaign**

Dear Sir/Madam:

The purpose of this correspondence is to provide preliminary information required by 49 CFR 573 and the National Traffic and Motor Vehicle Safety Act regarding a defect notification campaign we are initiating. We are attaching a current draft of the dealer technical bulletin for informational purposes. We will send under separate cover the owners notification for Agency review approval prior to close of business this week. The envelope format has previously been approved by the Agency for prior campaigns.

- I. Manufacturers Name: Yamaha Motor Company, Ltd.  
2500 Shingai  
Iwata, Japan
- Imported Vehicle Distributor: Yamaha Motor Corporation, U.S.A.  
6555 Katella Avenue  
Cypress, California 90630
2. Vehicles Affected: Make: Yamaha  
Models: 2002 - 2007 Model Year  
XV1700 motorcycles,
- Nominal Engine Displacement: XV1700 is 1700 cc
- Production Period: May 2001 - August 2006

3. The campaign relates to the motorcycle's pick-up coil.
4. Total number of subject vehicles: Current estimate: 18,000 units. This will be updated in a supplemental report as we finalize the affected VIN range.
5. VIN Range: See tentative range attached in draft Technical Bulletin. Likewise this will be updated in a subsequent report as data is confirmed.
6. The campaign involves the replacement of the pick-up coil assembly and mounting screws. Please refer to the attached draft Technical Bulletin which will be furnished to dealers upon completion describing the situation which is the subject of the campaign.
7. On January 30, 2007, Yamaha Motor Corporation, U.S.A. was informed by the manufacturer, Yamaha Motor Company, Ltd., that such a situation exists. This was determined pursuant to a quality control review, testing and a review of foreign models that use a substantially similarly part design.

We anticipate commencing dealer/owner notification shortly after the owner's notification letter is approved by NHTSA, the affected VIN range is ascertained and the Technical Bulletin revised. We anticipate sending the Agency the owner's notification letter for review/approval by 2-9-07. Assuming the Agency can approve the letter within 5 days of receipt (perhaps 2-16-07) we will have the letter and Technical Bulletin printed. Normal turn-around time is 3 working days for such printing. Hence the materials will be ready for mailing approximately 2-26-07. Final copies of these notification documents will be forwarded to the Agency as soon as possible.

In the event we can answer any questions or provide supplemental information, please do not hesitate to contact the undersigned. My direct telephone number is 714-761-7709. The fax number is 714-761-7836. My email is russ\_jura@yamaha-motor.com or contact Brad Franklin at 714-761-7842 (telephone), 714-229-7944 (Fax), brad\_franklin@yamaha-motor.com (email).

Sincerely,

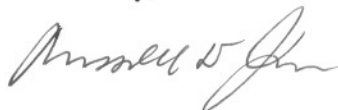

Russell D. Jura  
Senior Vice President  
and General Counsel

RDJ/dlb

Enclosures: Technical Bulletin  
Owners Notification  
cc: By Fed Ex and Facsimile  
Defects & Recall Information Analysis Division  
Mrs. Pat Wallace  
Mrs. Kelly Schuler  
(FAX: 202-366-0699)  
Mr. Robert Young (via email)

# Technical BULLETIN

©2007 YAMAHA MOTOR CORPORATION, U.S.A.

## RECALL

This modification has top priority. This bulletin must be performed immediately to ensure customer safety.

NOTE: Bulletins that announce a recall have an "R" at the end of the bulletin number.

## 2002 ~ 2007 XV17PC MODELS

### FACTORY MODIFICATION CAMPAIGN – Pick-Up Coil

#### i

#### INTRODUCTION

Yamaha Motor Corporation, U.S.A. has decided that a defect which relates to motor vehicle safety exists in all 2002 through 2007 XV17PC ("Warrior") model motorcycles. In affected motorcycles, the lead wires for the pick-up coil can break while the engine is running, which would cause the engine to stall and be impossible to restart. If this occurs while the motorcycle is being ridden, there could be an accident resulting in injury or death.

The pick-up coil mounting stay (bracket) is not sturdy enough to prevent vibration caused by magnetic force as the pick-up rotor passes the pick-up coil if the clearance between them is insufficient. The vibration can eventually weaken the lead wires and cause them to break.

To correct this defect, Yamaha is initiating a Factory Modification Campaign. Affected motorcycles must have the pick-up coil replaced with a new one that has a strengthened stay and also has a molded protector over the lead wires to protect them from vibration.

Yamaha is notifying all registered owners of affected motorcycles by mail. A copy of this letter is included in this bulletin. The customer should take the letter along with the affected motorcycle to an authorized Yamaha dealer for the modification.

A computer report listing all affected motorcycles invoiced to your dealership is included with this bulletin. Use the list to help ensure all motorcycles are modified. All sold motorcycles that have been registered with Yamaha will show the customer's name and address. Your dealership must notify the owner of any affected motorcycle that was actually sold but is listed as "unsold" in the report.

You must modify all affected motorcycles in your inventory as well as all customer-owned motorcycles brought to you for this service. Any affected motorcycle that you purchase from Yamaha in the future will also require modification. If you purchase a motorcycle from another dealer, check to see if the procedures in this bulletin have already been performed before you sell the motorcycle.

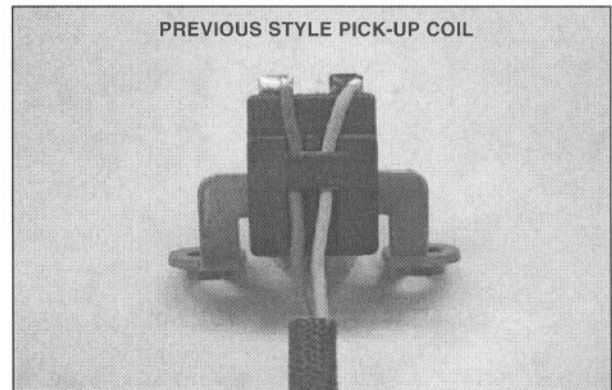

**Motorcycles that are affected should not be operated until they are modified. It is a violation of Yamaha policy for your dealership to deliver any affected motorcycles to customers until the procedures in this bulletin are performed.**

When the modification on each motorcycle is performed, follow the Warranty Information section of this bulletin to receive reimbursement. Be sure to use the Factory Modification Campaign procedures in Chapter 8 of the Warranty and Y.E.S. Handbook (LIT-11760-00-04).



## DEALER ACTION SUMMARY

### **Unsold**

**Units:** Replace the pick-up coil along with additional parts needed during PDI service.

### **Sold**

**Units:** Replace the pick-up coil along with additional parts needed according to this bulletin on all affected units. A letter is being mailed to all registered customers. A copy of the letter is included in this bulletin. Please contact any customers whose units were registered for warranty after xx/xx/07.

### **Parts**

**Required:** Yes, order a Pick-Up Coil Modification Kit for each affected unit. Each affected unit will also need an additional part: 2002 through 2005 models also need a lock washer; 2006 and 2007 models need a nut. See the Parts Information section for details.

Yamaha is manufacturing the kits for this modification as quickly as possible, but you will not be able to get kits for all customers at once. We are asking you to give priority to customers who plan to use their motorcycles as soon as possible after modification, and appreciate your patience while kits are being manufactured and delivered.

**Warranty:** Factory Modification Campaign. See the Warranty Information section of this bulletin. This modification applies to all affected units not previously modified regardless of ownership or warranty status. Warranty reimbursement for parts varies by model year and will be calculated automatically based upon the unit's Primary ID.

### **Notify**

**Customers:** Yes. You must immediately contact any customer whose motorcycle shows as unregistered on the enclosed report. Yamaha has sent letters to customers whose motorcycles were registered for warranty as of xx/xx/06.

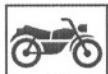

## AFFECTED RANGE

All 2002:  
XV17PCP  
XV17PCPC

All 2003:  
XV1700RCR  
XV1700RCRC

All 2004:  
XV17PCS  
XV17PCSC

All 2005:  
XV17PCT  
XV17PCTC

All 2006:  
XV17PCV  
XV17PCVC  
XV17PCMV  
XV17PCMVC

All 2007:  
XV17PCW  
XV17PCWC  
XV17PCMW  
XV17PCMWC



## SERVICE PROCEDURES

Refer to the Service Manual for detailed procedures.

1. Secure the unit in an upright position on a floor jack or other suitable support, then remove the seat, side cover, tool kit, and battery cover.

### NOTE:

Use a #30 tamper proof Torx® driver to remove the side cover's rear mounting bolt. Use a 4mm hex driver, to remove the front mounting screw. Pull the side cover off and remove the seat lock from the cover.

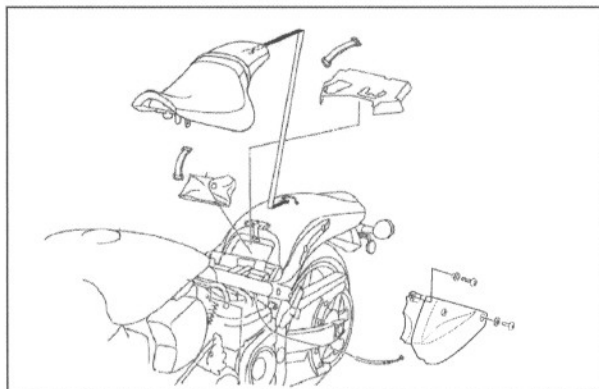

2. Remove the ECU, the wire harness cover, and the battery. Remove the battery ground cable.

### CAUTION:

**Be careful not to drop the battery as you lift it with the strap.**

3. Cut the band holding the wire harness to the battery box. Remove the reusable band hold the group of wire connectors.
4. Remove the seat latch bracket and the right rear fender support bolt. Lift the battery box enough to gain access to the sub tank's rear mounting bolt.
5. Remove the three fuel sub tank mounting bolts. Do not remove the fuel sub tank itself. Removing the bolts will allow the tank to be moved slightly to remove the pick-up coil harness.

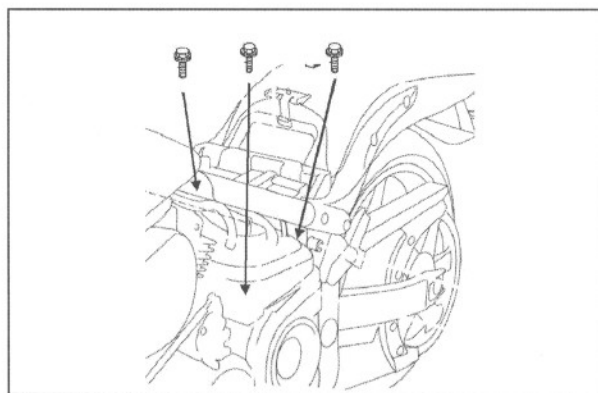
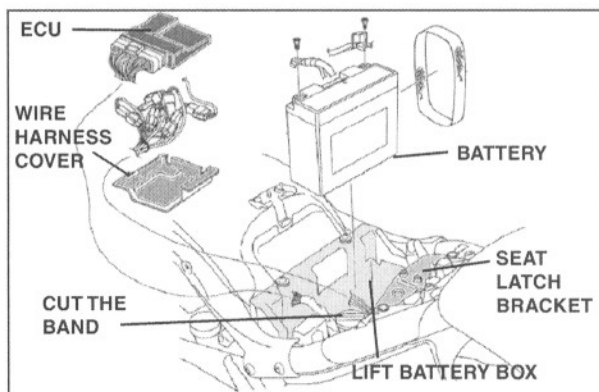

6. Loosen the rear axle, the brake stay bolt, and the drive belt adjusters. Remove the horn, drive pulley cover, pins and rollers, pulley, and pulley housing stay.
7. Derail the drive belt from the rear pulley, then pull the belt forward and out of the way to the left to allow the pulley housing to be removed. Remove the pulley housing.

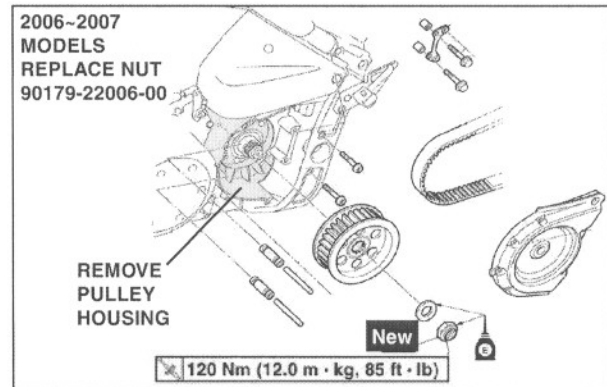
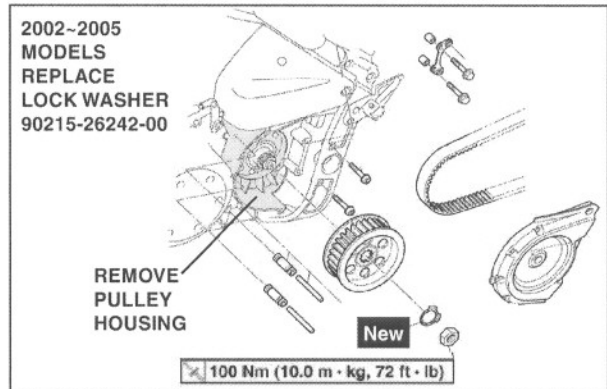

8. Disconnect the white connector for the pick-up coil harness (B & Gy wires on the pick-up coil side and B/L & Gy wires on the main harness side). Then, carefully noting the exact routing of the harness, remove it from top to bottom.

**NOTE:**

The harness is secured in four places:

- Move the fuel sub tank out of the way to the left to allow access to the two gray wire clamps on the side of the oil reservoir, then open both clamps and remove the harness.
- Cut the band below the wire clamps.
- Open the black wire clamp below the cut band.

9. When the harness is free, drain the engine oil, and then remove the left-side crankcase cover.

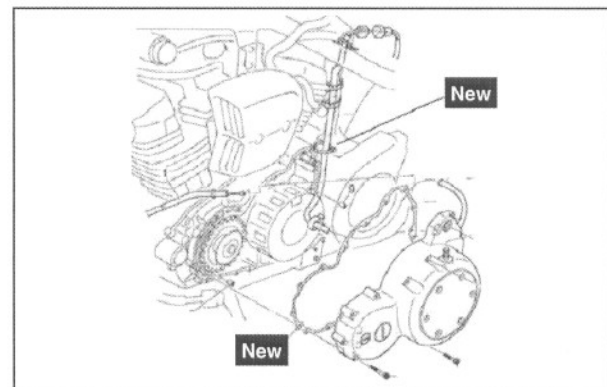

10. Remove the pick-up coil and wire harness from the crankcase cover. Install the new pick-up coil from the kit. Be sure to use the new screws from the modification kit.
11. Reinstall components in reverse order. Be sure to use the crankcase cover gasket and the bands from the kit, as well as the new lock washer (2002~2005 models) or nut (2006 and 2007 models) ordered separately.
12. Cut the wires of the old pick-up coil at the connector to prevent its accidental reuse, then properly tag and hold it and the lock washer or nut (as applicable) for 90 days from the date you are paid for the Recall Reimbursement.
13. When the modification is complete, put a punch mark next to the VIN as described in the Identification Procedure section.

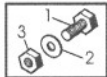
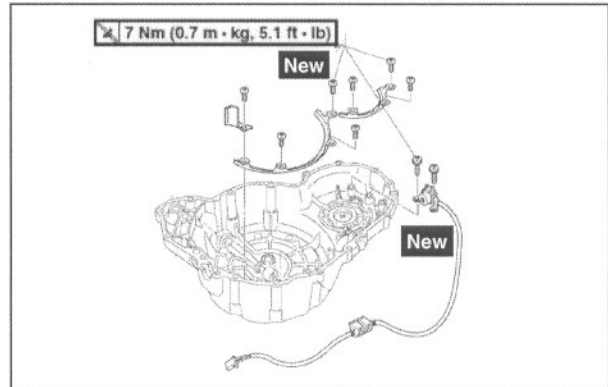

### PARTS INFORMATION

Order the Pick-Up Coil Modification Kit, plus either the lock washer or nut needed for the model year of the unit you are modifying.

Part Number	Description	Application	Dealer Cost
90891-30047-00	Pick-Up Kit <ul style="list-style-type: none"> <li>• Pick-Up Assembly</li> <li>• Crankcase Cover gasket</li> <li>• Band (3MA-82591-00-00)</li> <li>• Band (90464-13077-00)</li> <li>• Screw (90149-06004-00) qty 7</li> <li>• Screw (97607-06216-00) qty 2</li> </ul>	All models	\$XX.XX
90215-26241-00	Lock Washer	2002~2005 models only	\$ 2.18
90179-22006-00	Nut	2006~2007 models only	\$ 4.08

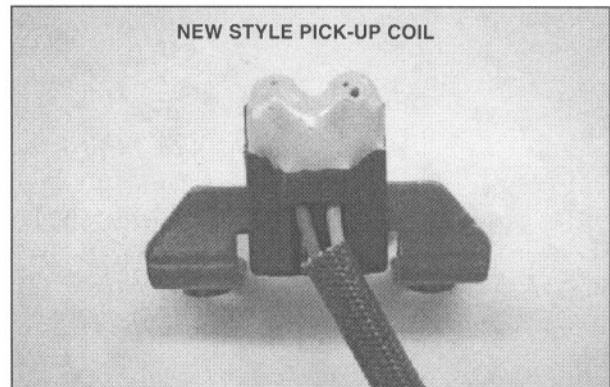
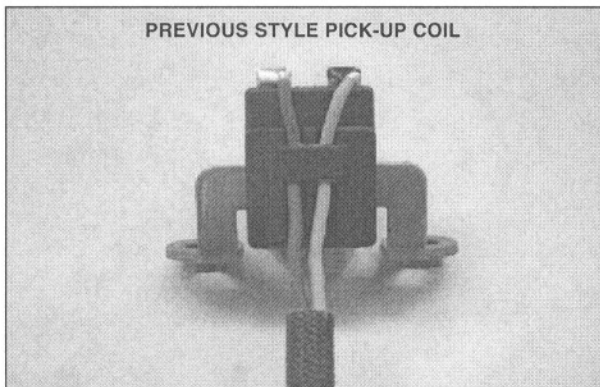





## IDENTIFICATION PROCEDURE

When the modification is complete, put a punch mark next to the Primary ID as shown. Check for this punch mark if you encounter an unfamiliar unit. You can also check unit status on YDS or by contacting your Regional Technical Advisor.

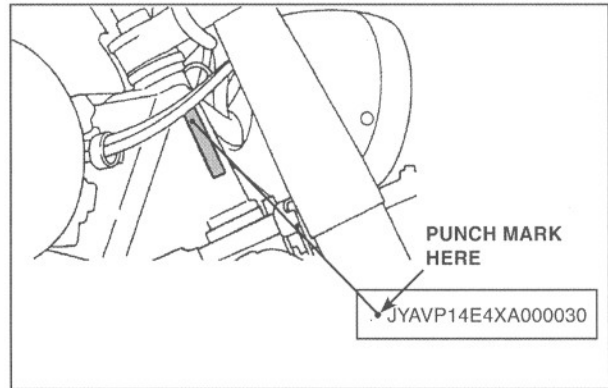

**NOTE:** Do not confuse this punch mark location with ones in other places next to the VIN. The illustration to the right shows the significance of the other punch marks.

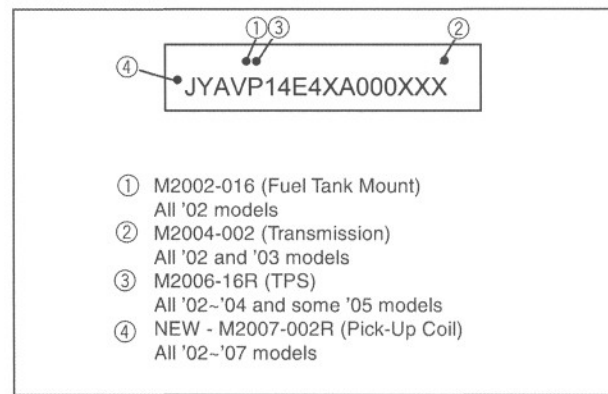

It is also possible to check for a modified unit by looking at the rubber grommet at the crankcase cover. New-style pick-up coil harnesses have a white mark on the grommet as shown.

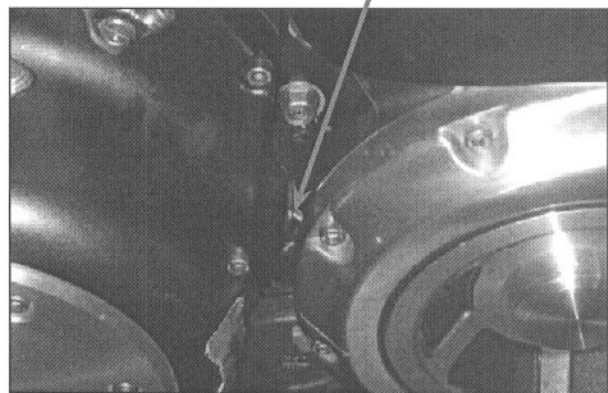
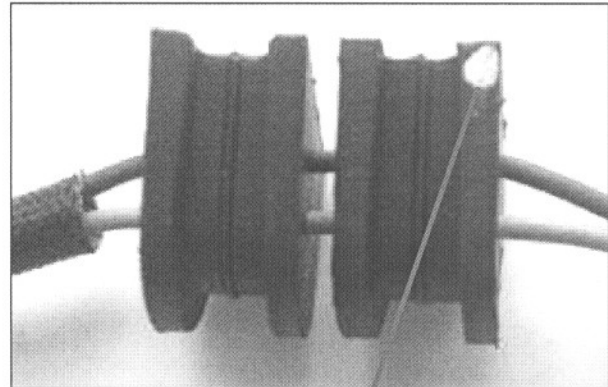





## WARRANTY INFORMATION

The owner of each warranty-registered unit will receive a letter announcing this campaign. The letter has a label that includes the Primary ID and Recall Number. Use this information when submitting for reimbursement as described below.

The modification is authorized for all motorcycles, both sold and unsold, regardless of ownership or warranty status. You do not need the customer's letter to perform the modification or to file for reimbursement.

Submit a Recall Request for the pick-up coil replacement as described below using Recall Number **9900xx**. Choose the status "**M**." You will be reimbursed a labor allowance of 1.0 hour, which includes a reimbursement amount for engine oil, plus the cost of the parts and your handling fee. You will be automatically be reimbursed for either the lock washer (2002~2005 units) or nut (2006~2007 units) based upon the Primary ID of the unit being modified.

### YDS:

When signed on to YDS, click on the Service Tab, and then "Recall Request-Add." This function will allow you to enter multiple Primary IDs for the same recall. Remember that YDS requires a 7-digit serial number, so use a "0" as the first digit. The system will check your submission instantly to make sure the Primary ID numbers you've entered are valid for the recall. You can check back the next day for your claim numbers to track your credit.

### MAIL:

Complete a recall Reimbursement Request (LIT-11790-00-03) as shown below:

Dealer Number				Dealer Name												
Recal Number				Primary I.D.							Date Completed				Status	
990036				RJ12E-0000XXX							11-30-2006				M I	
				-											M I	

If you have any questions about proper procedures for Factory Modification Campaigns, see Chapter 8 in your Warranty and Y.E.S. Handbook (LIT-11760-00-04).