

5PX1100-A230

(c) 2005-2009 Yamaha Motor Corporation, U.S.A.

Item	Part #	Description	Notes	Req
1	5PX-22110-00-00	REAR ARM COMP.		1
2	93317-42550-00	BEARING		2
3	5PX-22184-00-00	BUSH		1
4	5JJ-22128-00-00	COVER, THRUST 1		2
5	5PX-22141-00-00	SHAFT, PIVOT		1

6	90185-18104-00	NUT, SELF-LOCKING	1
7	90201-186M4-00	WASHER, PLATE	1
8	4KM-2219X-00-00	COVER	2
9	5PX-2217A-00-00	ARM, RELAY	1
10	4WM-2217M-00-00	ARM 1	2
11	93317-42060-00	BEARING	1
12	90387-122J6-00	COLLAR	1
13	90101-12002-00	BOLT	1
14	95617-12100-00	NUT, U	1
15	90201-12688-00	WASHER, PLATE	1
16	93317-41761-00	BEARING	2
17	90387-126T1-00	COLLAR	1
18	90101-12673-00	BOLT	1
19	95617-12100-00	NUT, U	1
20	90201-126A7-00	WASHER, PLATE	1
21	90201-13013-00	WASHER, PLATE	2
22	93317-31771-00	BEARING	1
23	93109-17071-00	OIL SEAL	2
24	90384-18157-00	BUSH, BIMETAL FORMED	4
25	93210-18397-00	O-RING	4
26	5PX-22311-00-00	CASE, CHAIN	1
27	5PX-2213J-01-00	STAY, CHAIN CASE	1
28	90387-064L2-00	COLLAR	2
29	90201-06063-00	WASHER, PLATE	1
30	90480-13004-00	GROMMET	3
31	95307-06600-00	NUT	1
32	90111-06038-00	BOLT	3
33	5PX-22312-00-00	CASE, CHAIN 2	1
34	5PX-22341-00-00	PLATE, GUIDE	1
35	90149-06298-00	SCREW	3
36	90119-06001-00	BOLT, WITH WASHER	1
37	90183-06053-00	NUT, SPRING	1
38	4DN-21268-00-00	SEAL	1
39	90387-065T2-00	COLLAR	2
40	90387-06372-00	COLLAR	1
41	5PX-22210-20-00	SHOCK ABSORBER ASSY, REAR	1
42	90387-1214E-00	COLLAR	1
43	90101-12695-00	BOLT	1
44	95607-12200-00	NUT, SELF-LOCKING	1
45	90387-127W0-00	COLLAR	1
46	90101-10659-00	BOLT	1
47	95617-10100-00	NUT, U	1
48	90201-101J1-00	WASHER, PLATE	1

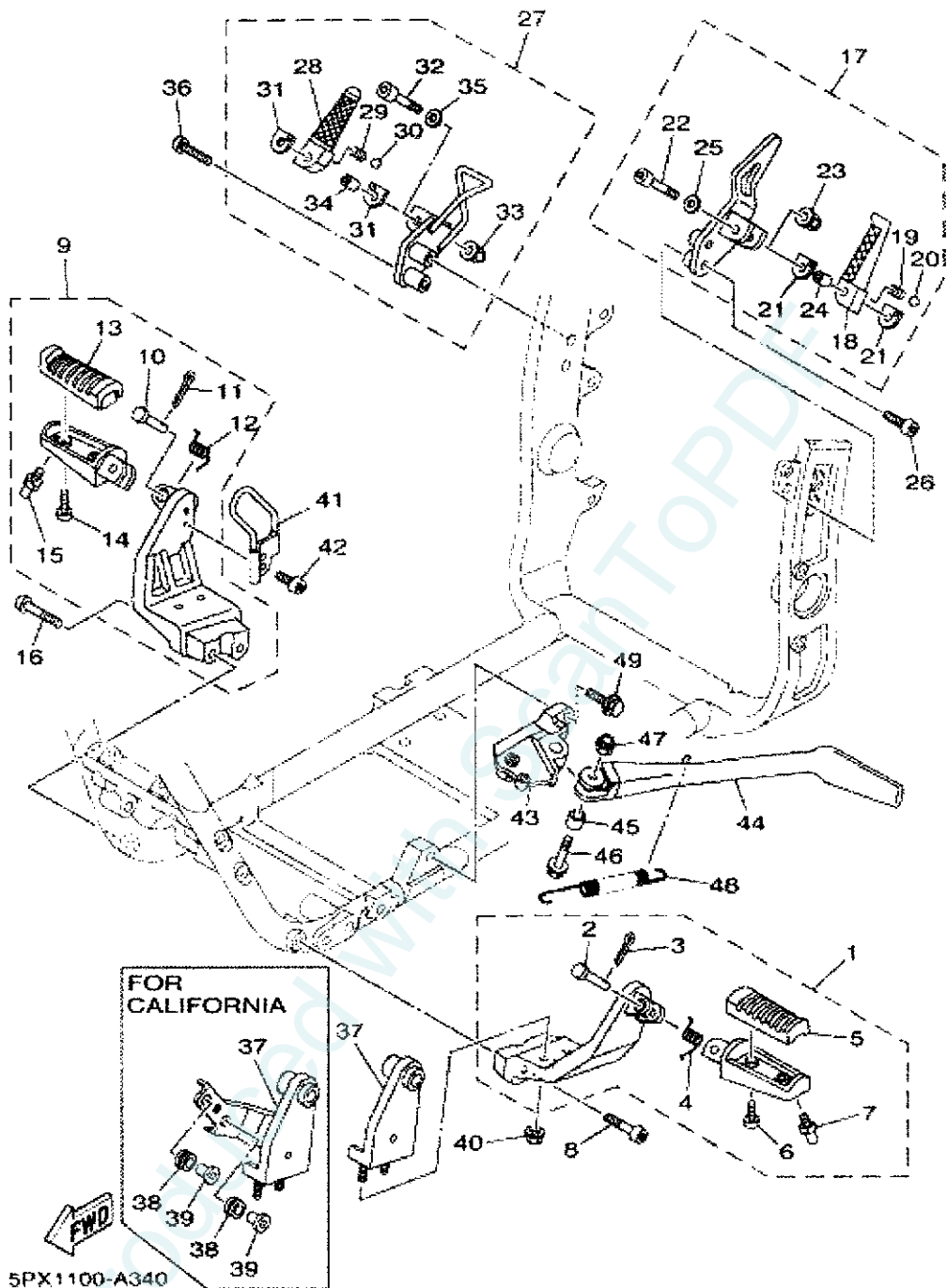

**FOR CALIFORNIA**

37

38

39

38

39

**FWD**

5PX1100-A340

(c) 2005-2009 Yamaha Motor Corporation, U.S.A.

Item	Part #	Description	Notes	Req
1	5PX-27410-00-00	FRONT FOOTREST ASSY (LEFT)		1
2	91701-08035-00	PIN, CLEVIS		1
3	91401-25015-00	PIN, COTTER		1
4	90508-20572-00	SPRING, TORSION		1
5	4BP-27413-00-00	COVER, FOOTREST		1

6	90157-05079-00	SCREW, PAN HEAD	2
7	5PX-27435-00-00	BOLT	1
8	92014-10050-00	BOLT, BUTTON HEAD	2
9	5PX-27420-00-00	FRONT FOOTREST ASSY (RIGHT)	1
10	91701-08035-00	PIN, CLEVIS	1
11	91401-25015-00	PIN, COTTER	1
12	90508-20572-00	SPRING, TORSION	1
13	4BP-27413-00-00	COVER, FOOTREST	1
14	90157-05079-00	SCREW, PAN HEAD	2
15	5PX-27435-00-00	BOLT	1
16	92014-10050-00	BOLT, BUTTON HEAD	2
17	5PX-27430-00-00	REAR FOOTREST ASSY 1	1
18	5PX-27431-00-00	FOOTREST, REAR 1	1
19	90501-15001-00	SPRING, COMPRESSION	1
20	93501-04011-00	BALL	1
21	2NT-27437-00-00	WASHER, SPECIAL	2
22	91380-06040-00	BOLT	1
23	95604-06200-00	NUT, U FLANGE	1
24	90387-06554-00	COLLAR	1
25	90201-066G5-00	WASHER, PLATE	1
26	90111-10010-00	BOLT	2
27	5PX-27440-00-00	REAR FOOTREST ASSY 2	1
28	5PX-27441-00-00	FOOTREST, REAR 2	1
29	90501-15001-00	SPRING, COMPRESSION	1
30	93501-04011-00	BALL	1
31	2NT-27437-00-00	WASHER, SPECIAL	2
32	91380-06040-00	BOLT	1
33	95604-06200-00	NUT, U FLANGE	1
34	90387-06554-00	COLLAR	1
35	90201-066G5-00	WASHER, PLATE	1
36	90111-10011-00	BOLT	2
37	5PX-27443-00-00	BRACKET 3	1
	5PX-27443-10-00	BRACKET 3	1
38	90480-13163-00	GROMMET	2
39	90387-062L2-00	COLLAR	2
40	95607-08200-00	NUT, SELF-LOCKING	2
41	5PX-2721A-00-00	GUIDE, PLATE	1
42	92017-06010-00	BOLT, BUTTON HEAD	2
43	5PX-27321-00-00	BRACKET, SIDE STAND	1
44	5PX-27311-00-00	STAND, SIDE	1
45	90387-1215U-00	COLLAR	1
46	90105-12018-00	BOLT, FLANGE	1
47	90185-12119-00	NUT, SELF-LOCKING	1
48	90506-35003-00	SPRING, TENSION	1

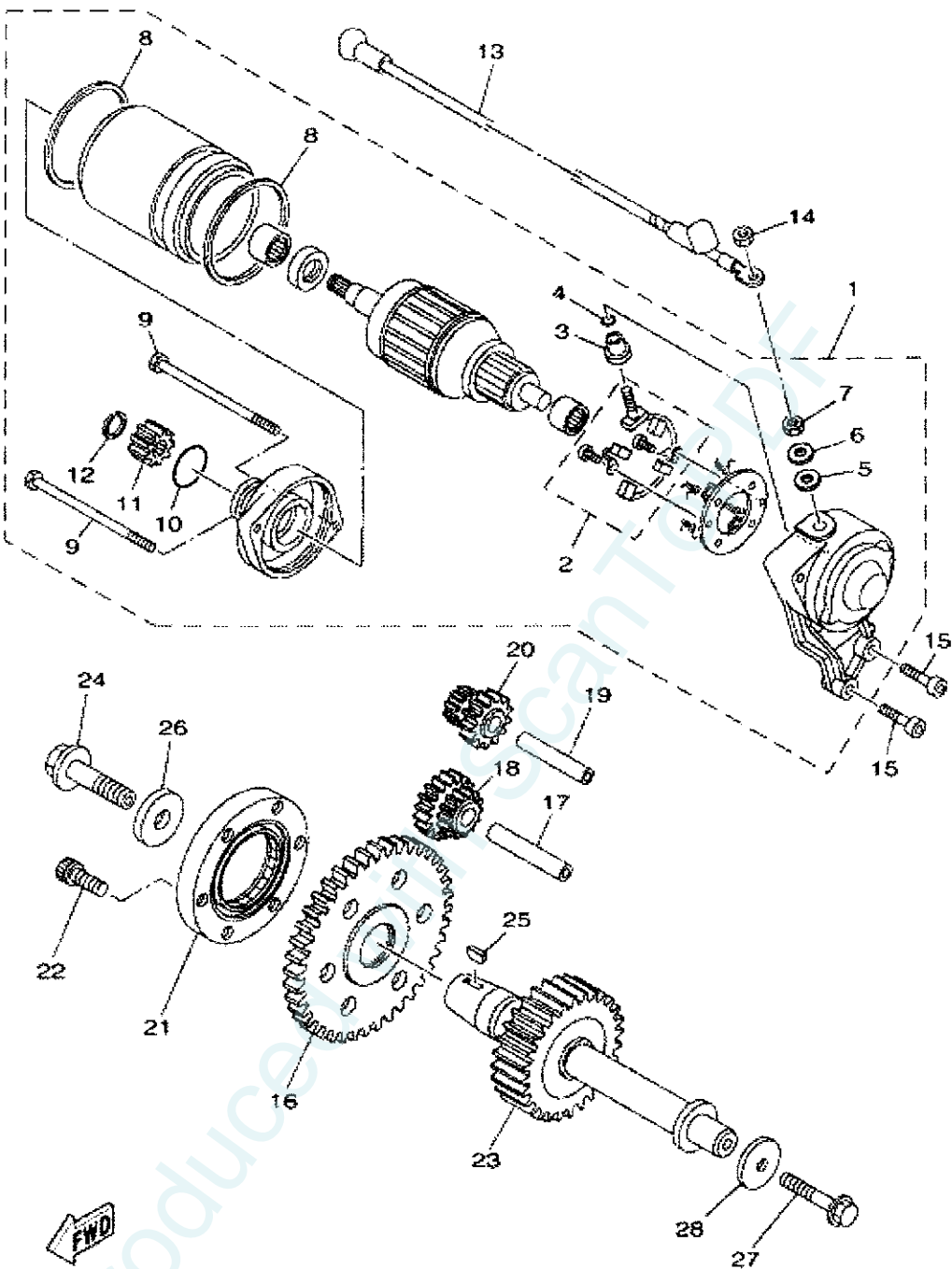

5PX1100-A140

(c) 2005-2009 Yamaha Motor Corporation, U.S.A.

Item	Part #	Description	Notes	Req
1	5PX-81890-00-00	MOTOR ASSY		1
2	5PX-81801-00-00	BRUSH SET		1
3	5PX-8182G-00-00	BUSH, TERMINAL		1
4	93210-06001-00	O-RING		1
5	5PX-8181L-00-00	WASHER, PLAIN		1

6	90201-06726-00	WASHER, PLATE	1
7	95304-06700-00	NUT	1
8	5PX-81861-00-00	GASKET	2
9	5PX-81846-00-00	SCREW	2
10	93210-25711-00	O-RING	2
11	5PX-15511-00-00	GEAR, STARTING MOTOR	1
12	99009-10800-00	CIRCLIP	1
13	5PX-8183G-00-00	CORD COMP.	1
14	95304-06700-00	NUT	1
15	91314-06025-00	BOLT	2
16	4WM-15515-00-00	GEAR 3	1
17	4WM-15522-00-00	SHAFT 2	1
18	4WM-15517-00-00	GEAR, IDLER 2	1
19	4WM-15521-00-00	SHAFT 1	1
20	4WM-15512-00-00	GEAR, IDLER 1	1
21	4WM-15590-00-00	STARTER ONE-WAY ASSY	1
22	90110-08015-00	BOLT, HEXAGON SOCKET HEAD	6
23	5PX-15659-00-00	SHAFT	1
24	90105-12005-00	BOLT, FLANGE	1
25	90280-05048-00	KEY, WOODRUFF	1
26	90201-121H0-00	WASHER, PLATE	1
27	95817-08045-00	BOLT, FLANGE	1
28	4WM-15653-00-00	WASHER	1

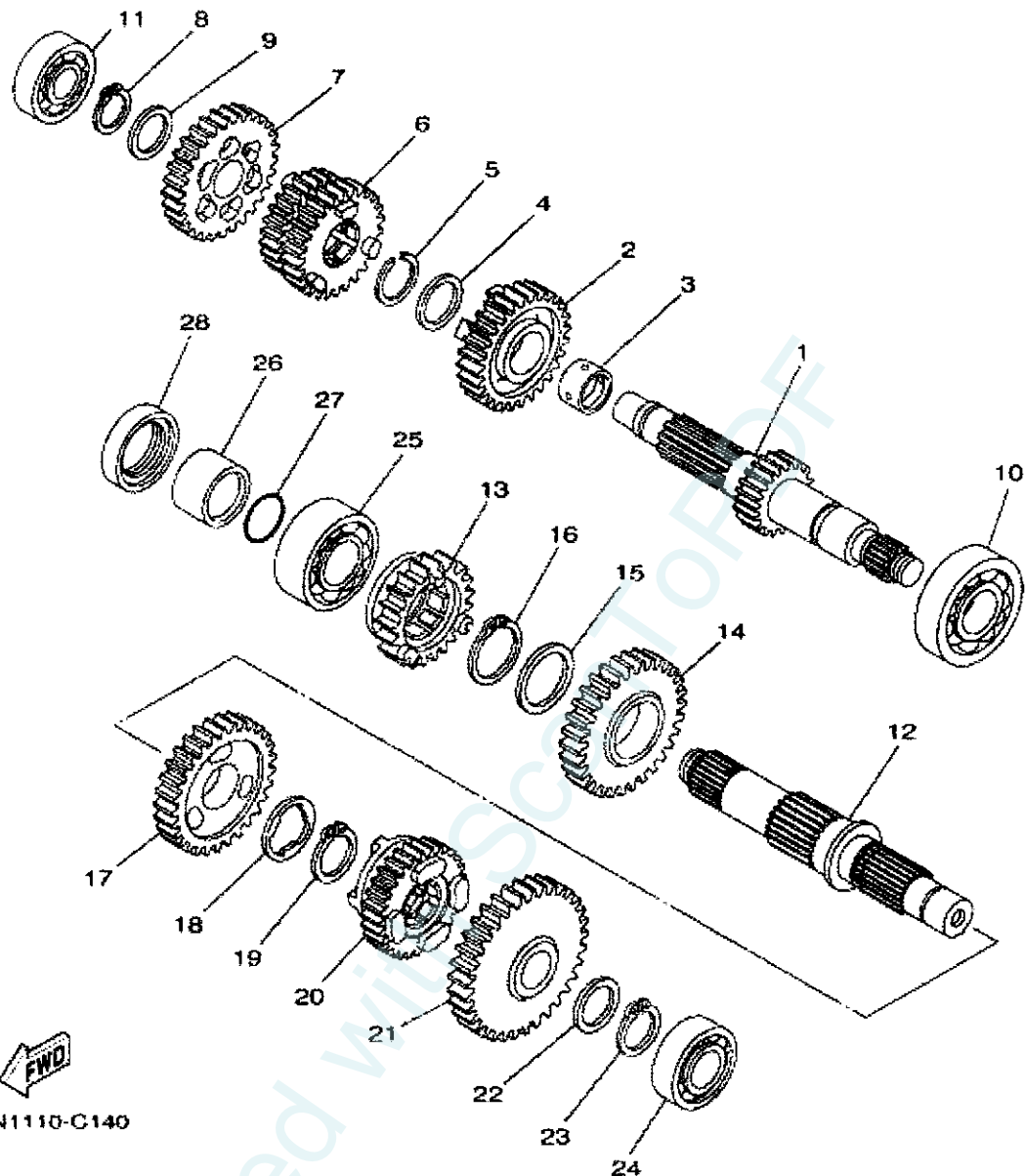

5VN1110-C140

**NOTE A: WHEN REPLACING ANY OF THE FOLLOWING, "AXLE, MAIN (16T) 5PX-17411-A0-00", "GEAR, 4TH PINION (31T) 5PX-17141-20-00", "COLLAR 90387-281T8-00" AND "WASHER 90209-250130-00", THEY MUST BE REPLACED AND/OR USED AS A SET.**

(c) 2005-2009 Yamaha Motor Corporation, U.S.A.

Item	Part #	Description	Notes	Req
1	5PX-17411-A0-00	AXLE, MAIN (16T)	SEE NOTE A	1
2	5PX-17141-20-00	GEAR, 4TH PINION (31T)	SEE NOTE A	1
3	90387-281T8-00	COLLAR	SEE NOTE A	1
4	90209-250130-00	WASHER	SEE NOTE A	1
5	93440-28062-00	CIRCLIP		1

6	5PX-17121-00-00	GEAR, 2ND PINION (25T/19T)	1
7	5PX-17151-00-00	GEAR, 5TH PINION (30T)	1
8	93410-23056-00	CIRCLIP	1
9	90201-232K5-00	WASHER, PLATE	1
10	93306-37806-00	BEARING	1
11	93306-30441-00	BEARING	1
12	4WM-17421-00-00	AXLE, DRIVE	1
13	5PX-17251-00-00	GEAR, 5TH WHEEL (24T)	1
14	4NK-17221-01-00	GEAR, 2ND WHEEL (30T)	1
15	90209-32231-00	WASHER	1
16	93440-34025-00	CIRCLIP	1
17	4NK-17231-01-00	GEAR, 3RD WHEEL (29T)	1
18	90209-27192-00	WASHER	1
19	93440-30077-00	CIRCLIP	1
20	5PX-17241-01-00	GEAR, 4TH WHEEL (24T)	1
21	5PX-17211-00-00	GEAR, 1ST WHEEL (38T)	1
22	90201-258K6-00	WASHER, PLATE (0.9T)	1
23	93410-25017-00	CIRCLIP	1
24	93306-20550-00	BEARING (B6205DU8)	1
25	93305-20607-00	BEARING	1
26	90387-3015P-00	COLLAR	1
27	93210-30660-00	O-RING	1
28	93103-38184-00	OIL SEAL	1



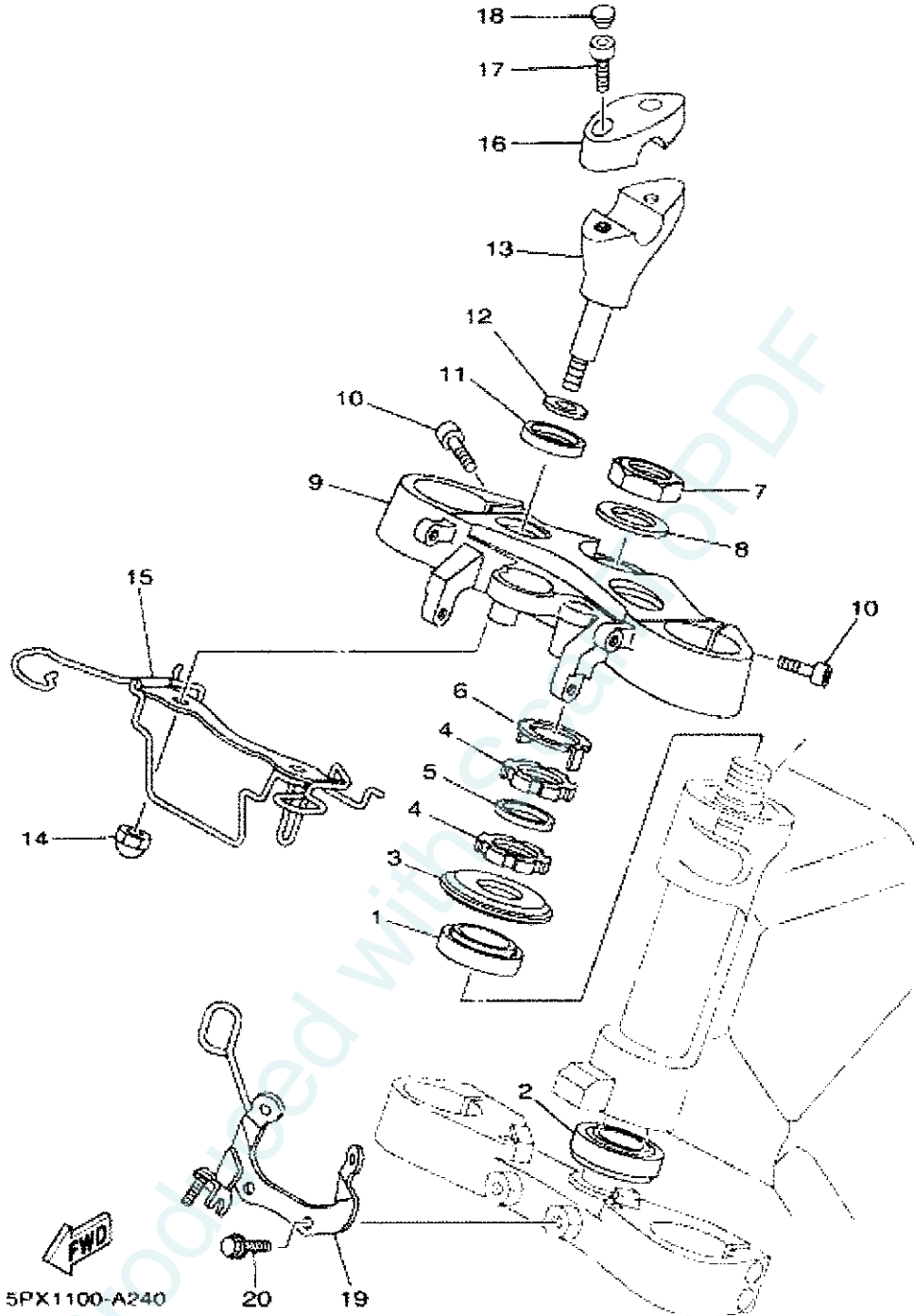

(c) 2005-2009 Yamaha Motor Corporation, U.S.A.

Item	Part #	Description	Notes	Req
1	93332-00091-00	BEARING		1
2	93332-00008-00	BEARING		1
3	4XV-23415-01-00	COVER, BALL RACE 1		1
4	90179-30691-00	NUT		2
5	90202-30235-00	WASHER, PLATE		1

6	4XV-23418-00-00	WASHER, SPECIAL	1
7	90170-28419-00	NUT	1
8	90201-281U8-00	WASHER, PLATE	1
9	5PX-W2341-00-00	CROWN, HANDLE	1
10	91314-08025-00	BOLT	4
11	3DM-23445-00-00	DAMPER	2
12	90201-14220-00	WASHER, PLATE	2
13	5PX-23442-00-00	HOLDER, HANDLE LOWER	2
14	90176-12052-00	NUT, CROWN	2
15	5PX-23389-00-00	GUIDE, CABLE	1
16	4NK-23441-00-00	HOLDER, HANDLE UPPER	2
17	91314-08025-00	BOLT	4
18	90338-08163-00	PLUG	4
19	5PX-23174-00-00	STAY, HEADLIGHT	1
20	95027-08016-00	BOLT, FLANGE	2

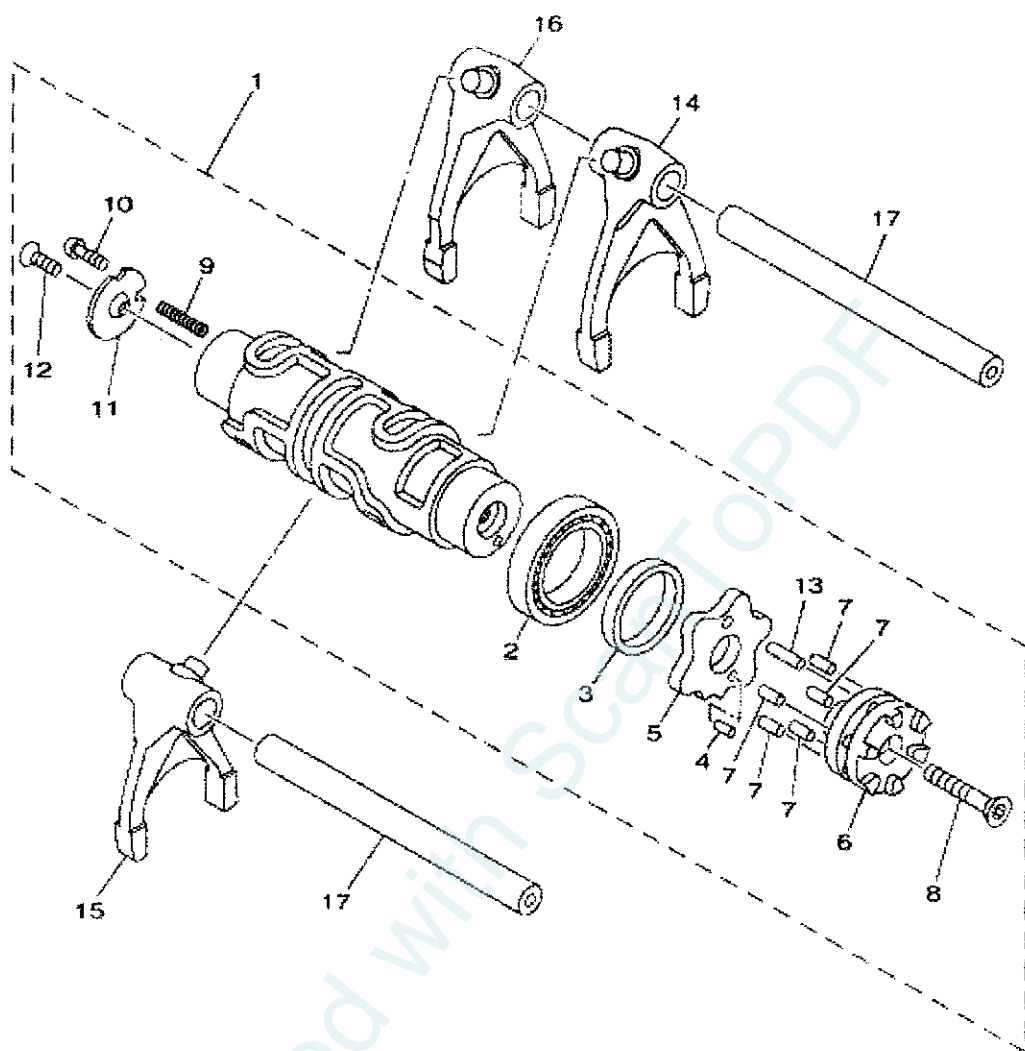

5PX1100-A180

(c) 2005-2009 Yamaha Motor Corporation, U.S.A.

Item	Part #	Description	Notes	Req
1	5PX-18540-00-00	SHIFT CAM ASSY		1
2	93306-90602-00	BEARING		1
3	90560-30234-00	SPACER		1
4	93603-10049-00	PIN, DOWEL		1
5	4NK-18141-00-00	PLATE, STOPPER		1

6	4NK-18185-00-00	SEGMENT	1
7	93604-12037-00	PIN, DOWEL	1
8	90151-06013-00	SCREW, COUNTERSUNK	1
9	90501-06022-00	SPRING, COMPRESSION	1
10	4UN-18542-00-00	POINT, NEUTRAL	1
11	4UN-18566-00-00	PLATE, SIDE 2	1
12	90149-05011-00	SCREW	1
13	93604-16092-00	PIN, DOWEL	1
14	4WM-18511-00-00	FORK, SHIFT 1	1
15	4WM-18512-00-00	FORK, SHIFT 2	1
16	5PX-18513-00-00	FORK, SHIFT 3	1
17	4NK-18531-00-00	BAR, SHIFT FORK GUIDE 1	2

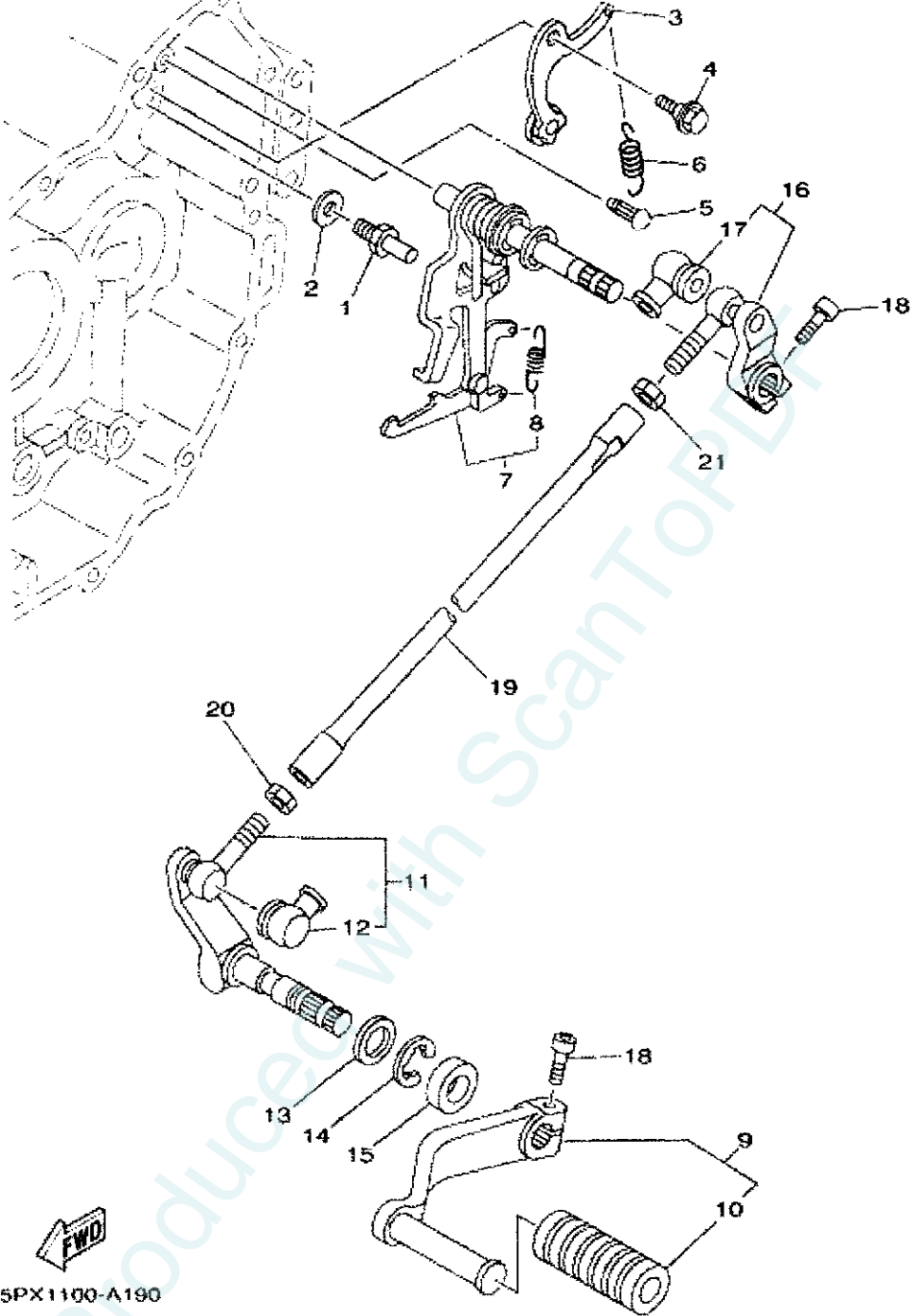

(c) 2005-2009 Yamaha Motor Corporation, U.S.A.

Item	Part #	Description	Notes	Req
1	90109-08025-00	BOLT		1
2	90201-08085-00	WASHER, PLATE		1
3	26H-18140-02-00	STOPPER LEVER ASSY		1
4	90109-06048-00	BOLT		1
5	132-16346-00-00	HOOK, SPRING		1

6	90506-18007-00	SPRING, TENSION	1
7	4WM-18101-01-00	SHIFT SHAFT ASSY	1
8	90506-08227-00	SPRING, TENSION	1
9	5PX-18110-00-00	SHIFT PEDAL ASSY	1
10	4NK-18113-10-00	COVER, SHIFT PEDAL	1
11	5PX-18164-00-00	KNOB, SHIFTER	1
12	2H9-18154-00-00	COVER, DUST	1
13	90201-144J2-00	WASHER, PLATE	1
14	99001-12600-00	CIRCLIP	1
15	5PX-18154-00-00	COVER, DUST	1
16	4WM-18150-01-00	SHIFT LEVER ASSY	1
17	2H9-18154-00-00	COVER, DUST	1
18	91314-06020-00	BOLT	2
19	5PX-18115-00-00	ROD, SHIFT	1
20	95304-08700-00	NUT	1
21	90170-08358-00	NUT	1

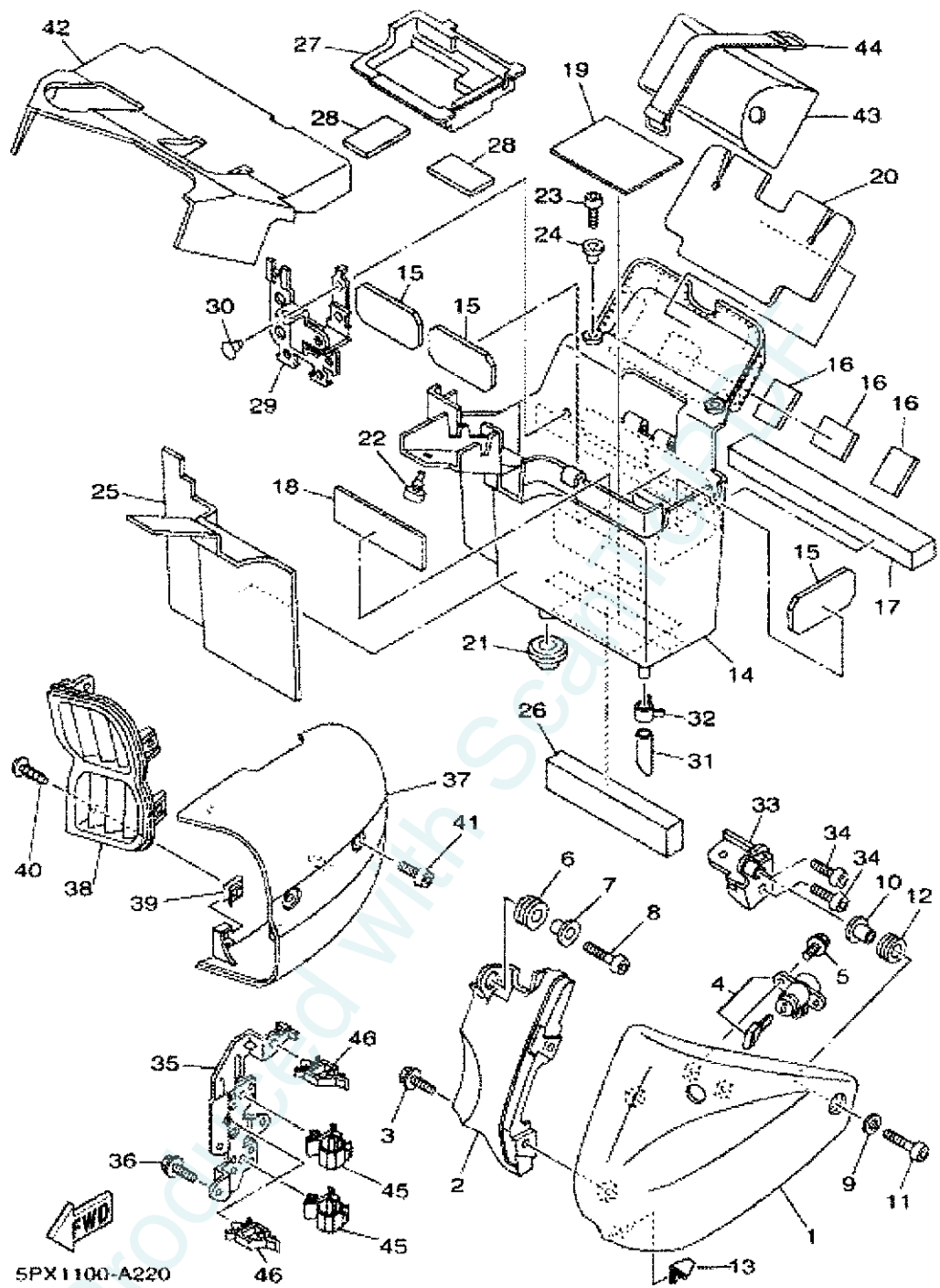

5PX1100-A220

(c) 2005-2009 Yamaha Motor Corporation, U.S.A.

Item	Part #	Description	Notes	Req
1	5PX-21711-00-P0	COVER, SIDE 1	Use for Color MAT BLACK 2 ( MBL2 / 0582 )	1
2	5PX-2117X-00-P0	COVER 9	Use for Color MAT BLACK 2 ( MBL2 / 0582 )	1
3	90105-06020-00	BOLT, FLANGE		2
4	5PX-W2470-00-00	SEAT LOCK ASSY		1
5	95027-06016-00	BOLT, FLANGE		2

6	90480-14323-00	GROMMET	1
7	90387-066Y6-00	COLLAR	1
8	92014-06020-00	BOLT, BUTTON HEAD	1
9	90201-06M01-00	WASHER, PLATE	1
10	90387-06638-00	COLLAR	1
11	90149-06023-00	SCREW	1
12	90480-12067-00	GROMMET	1
13	5PX-2171H-00-00	GUIDE	1
14	5PX-2177G-00-00	BOX, BATTERY	1
15	5PX-21652-00-00	PROTECTOR	3
16	5JW-2139X-00-00	DAMPER	3
17	5PX-21747-00-00	DAMPER	1
18	5PX-21778-00-00	DAMPER, LOCATING 1	1
19	5PX-21779-00-00	DAMPER, LOCATING 2	1
20	5PX-2174Y-01-00	DAMPER	1
21	90480-20384-00	GROMMET	1
22	35T-24724-00-00	DAMPER, SEAT	1
23	92017-06016-00	BOLT, BUTTON HEAD	2
24	90387-07717-00	COLLAR	2
25	5PX-21732-00-00	SEAL 1	1
26	5PX-2174X-00-00	DAMPER	1
27	5PX-82129-00-00	COVER, BATTERY	1
28	5JW-2139X-00-00	DAMPER	2
29	5PX-2172K-00-00	BRACKET 1	1
30	90269-07077-00	RIVET	2
31	90445-11027-00	HOSE	1
32	90467-11090-00	CLIP	1
33	5PX-2175T-00-00	BRACKET 1	1
34	92017-06016-00	BOLT, BUTTON HEAD	2
35	5PX-2174E-00-00	STAY, SIDE COVER 2	1
36	95027-06012-00	BOLT, FLANGE	2
37	5PX-21731-00-00	COVER, SIDE 3	1
38	5PX-2837N-00-00	GRILL, AIR INTAKE 1	1
39	90183-05042-00	NUT, SPRING	4
40	97707-50012-00	SCREW, TAPPING	4
41	90149-06302-00	SCREW	2
42	5PX-24796-00-00	COVER	1
43	5PX-28100-10-00	TOOL KIT	1
44	120-82131-00-00	BAND, BATTERY	1
45	90464-20002-00	CLAMP	2
46	90464-16021-00	CLAMP	2



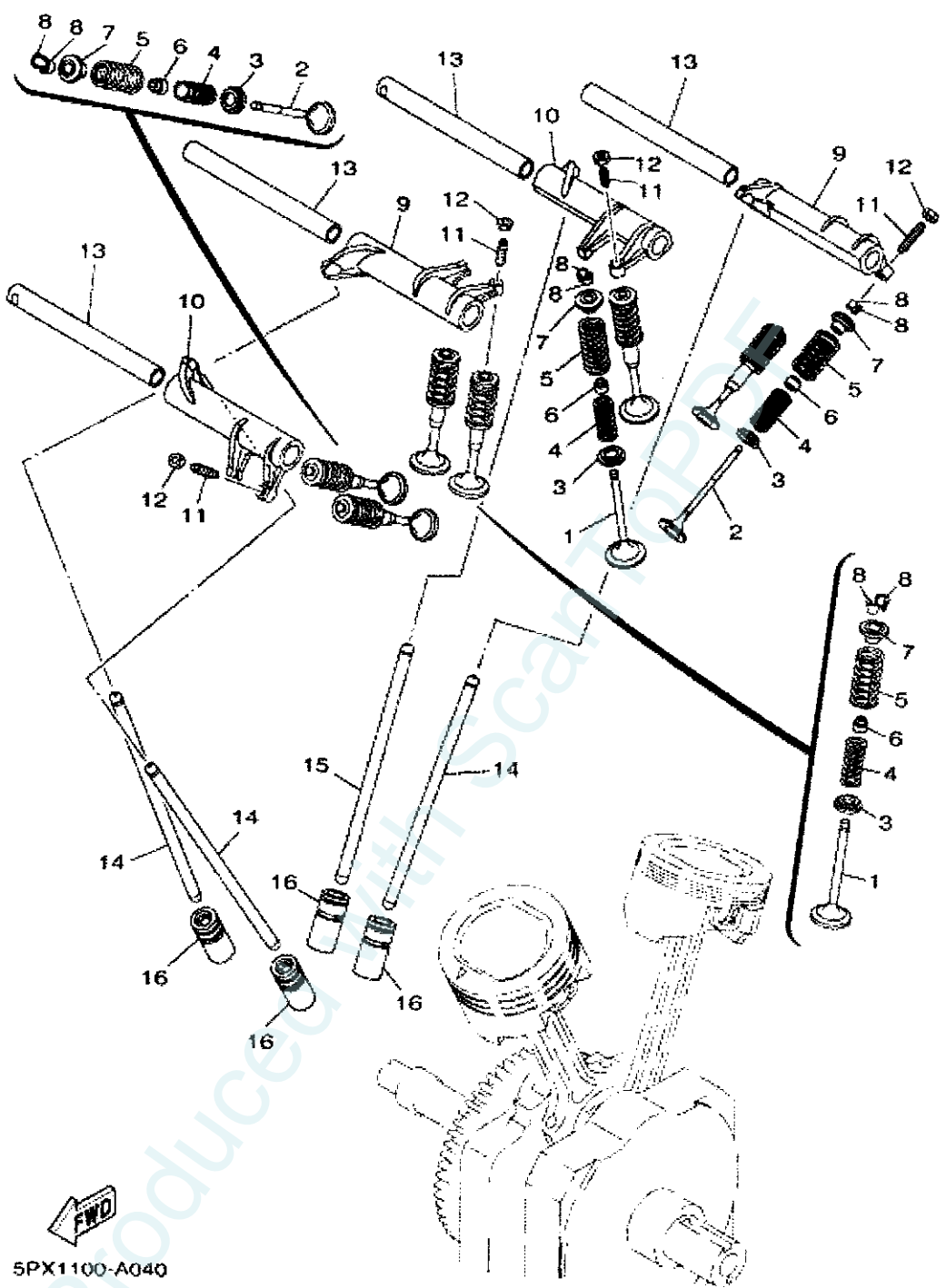

5PX1100-A040

(c) 2005-2009 Yamaha Motor Corporation, U.S.A.

Item	Part #	Description	Notes	Req
1	4WM-12111-00-00	VALVE, INTAKE		4
2	4WM-12121-00-00	VALVE, EXHAUST		4
3	26H-12116-00-00	SEAT, VALVE SPRING		8
4	4WM-12113-00-00	SPRING, VALVE INNER		8
5	4WM-12114-00-00	SPRING, VALVE OUTER		8

6	4KM-12119-00-00	SEAL, VALVE STEM	8
7	26H-12117-00-00	RETAINER, VALVE SPRING	8
8	4G0-12118-00-00	COTTER, VALVE	16
9	5PX-12151-00-00	ARM, VALVE ROCKER	2
10	5PX-12161-00-00	ARM, VALVE ROCKER 2	2
11	31G-12159-02-00	SCREW, VALVE ADJUSTING	4
12	31G-12158-00-00	NUT, LOCK	4
13	5PX-12146-00-00	SHAFT, ROCKER	4
14	5PX-12154-00-00	ROD, VALVE PUSH	3
15	5PX-12144-00-00	ROD, VALVE PUSH 2	1
16	4WM-12153-00-00	LIFTER, VALVE	4

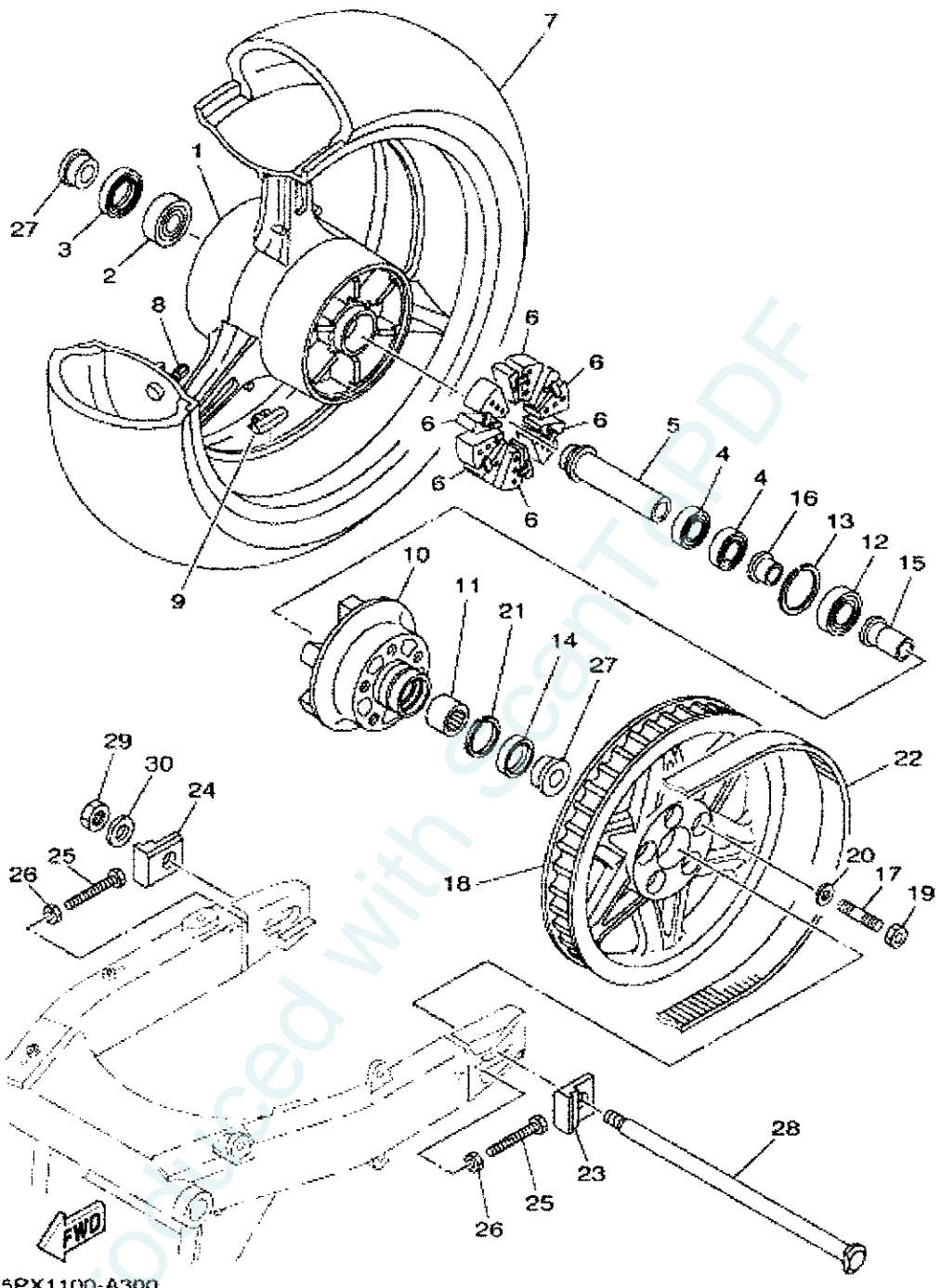

5PX1100-A300

(c) 2005-2009 Yamaha Motor Corporation, U.S.A.

Item	Part #	Description	Notes	Req
1	5PX-25338-01-7B	CAST WHEEL, REAR	BIB2	1
2	93306-30437-00	BEARING		1
3	93106-30029-00	OIL SEAL		1
4	93306-00416-00	BEARING (B6004RS)		2
5	5PX-25317-00-00	SPACER, BEARING		1

6	4WM-25364-00-00	DAMPER		6
7	94120-17008-00	TIRE (200/50 ZR-17M/C 75WBT020R UR BRIDGESTONE		1
	94120-17009-00	TIRE (200/50 ZR-17M/C 75WD220) UR DUNLOP		1
8	93900-00030-00	VALVE, RIM (TR412)		1
9	5MT-25398-00-00	BALANCER, WHEEL (10G)	UN	1
	5MT-25398-10-00	BALANCER, WHEEL (20G)	UN	1
	5MT-25398-20-00	BALANCER, WHEEL (30G)	UN	1
10	5PX-25366-00-00	CLUTCH, HUB		1
11	93317-32677-00	BEARING		1
12	93306-20551-00	BEARING		1
13	99009-52500-00	CIRCLIP		1
14	93106-30004-00	OIL SEAL		1
15	4WM-25376-00-00	COLLAR, WHEEL		1
16	4WM-25377-00-00	COLLAR, WHEEL		1
17	95617-12630-00	BOLT, STUD		5
18	5PX-25470-00-00	SPROCKET, DRIVEN (70T)		1
19	95614-12100-00	NUT, U		5
20	90201-126A7-00	WASHER, PLATE		5
21	93450-35015-00	CIRCLIP		1
22	5PX-46241-00-00	V-BELT		1
23	5PX-25388-00-00	PULLER, CHAIN 1		1
24	5PX-25389-00-00	PULLER, CHAIN 2		1
25	90101-08766-00	BOLT		2
26	95307-08600-00	NUT		2
27	90387-202X9-00	COLLAR		2
28	5PX-25381-00-00	AXLE, WHEEL		1
29	90185-18167-00	NUT, SELF-LOCKING		1
30	90201-185R7-00	WASHER, PLATE		1



6	5PX-2471A-00-00	STAY, SEAT	1
7	95607-06200-00	NUT, SELF U-FLANGE	2
8	90201-06380-00	WASHER, PLATE	2
9	509-24724-00-00	DAMPER, SEAT	4
10	22W-24741-00-00	PAD, SEAT	5
11	5PX-24723-01-00	DAMPER, SEAT	1
12	4BP-24780-00-00	SEAT LOCK ASSY	1
13	4BP-24792-00-00	PLATE	1
14	95707-06500-00	NUT, FLANGE	2
15	5PX-2478E-00-00	CABLE, SEAT LOCK	1
16	5PX-2475N-00-00	BRACKET	1
17	5PX-2475R-00-00	BRACKET 6	1
18	95027-08016-00	BOLT, FLANGE	4
19	5PX-2476U-00-00	PROTECTOR,1	1
20	5PX-2476V-00-00	PROTECTOR,2	1
21	5PX-21341-00-00	BRACKET, SEAT 1	1
22	5PX-21735-00-00	SEAL 2	2
23	95817-08020-00	BOLT, FLANGE	2